

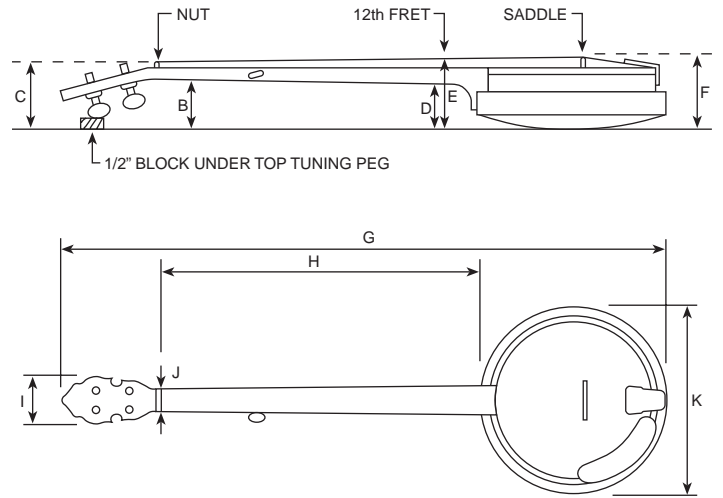

Custom Fitted  
Fibreglass  
Instrument Cases

# BANJO ORDER FORM

- 1/2" A - Table to bottom of top Tuning Peg
- \_\_\_\_\_ B - Table to bottom of Neck at 2nd Fret
- \_\_\_\_\_ C - Table to top of String at 2nd Fret
- \_\_\_\_\_ D - Table to bottom of Neck at 12th Fret
- \_\_\_\_\_ E - Table to top of String at 12th Fret
- \_\_\_\_\_ F - Table to top of Bridge
- \_\_\_\_\_ G - Length of Banjo (overall)
- \_\_\_\_\_ H - Length of Neck (Nut to Pot)
- \_\_\_\_\_ I - Width of Headstock
- \_\_\_\_\_ J - Width of Neck at Nut
- \_\_\_\_\_ K - Diameter of Resonator or the Pot to the outside lugs (whichever is greater)



## MEASURING INSTRUCTIONS

- STEP 1:** Place the instrument on a table and rest the top Tuning Peg on a 1/2" block.
- STEP 2:** Take measurements to the nearest 1/16".
- STEP 3:** Does your Banjo have "Scruggs" style tuners, or do you intend to put some on? Please advise us so we can alter the padding for them.
- STEP 4:** Note anything unusual about your Banjo. Does it have any external knobs, pickups, strap pins or anything else that will require special cutting of the padding? If so, please include the measurements for these items and note their exact placement on your plans.

Name: \_\_\_\_\_

Address: \_\_\_\_\_

City: \_\_\_\_\_

Prov/State: \_\_\_\_\_ Postal/Zip Code: \_\_\_\_\_

Tel: \_\_\_\_\_

S.S.N. (USA only): \_\_\_\_\_

Guitar Make: \_\_\_\_\_

Model: \_\_\_\_\_

Personalized nameplate: 2 lines, up to 10 letters per line.  
Please print the information as it is to appear on the label:

Please see price list for current prices

STANDARD <input type="checkbox"/> or DELUXE <input type="checkbox"/> Case	
EXTERIOR Color (check one): Red <input type="checkbox"/> Green <input type="checkbox"/> Blue <input type="checkbox"/> White <input type="checkbox"/> Brown <input type="checkbox"/> Black <input type="checkbox"/> Grey <input type="checkbox"/>	
INTERIOR Color (check one): Red <input type="checkbox"/> Green <input type="checkbox"/> Silver <input type="checkbox"/> Beige <input type="checkbox"/> Rose <input type="checkbox"/> Black <input type="checkbox"/> Blue <input type="checkbox"/> Wine <input type="checkbox"/>	
LOCKING CATCHES (Specify how many)	
SHOULDER STRAP	
OTHER	
ANOTHER OTHER	
SHIPPING & HANDLING	
<b>SUBTOTAL</b>	
GST (Canadian Residents Only)	
<b>TOTAL ENCLOSED</b>	